



Development of New Model Residential Fuel Cell Systems

Akira Sano, Tokyo Gas Co., Ltd., Japan

Kei Ogasawara, Tokyo Gas Co., Ltd., Japan

Kosuke Kobayashi, Tokyo Gas Co., Ltd., Japan

Takayuki Watanabe, Tokyo Gas Co., Ltd., Japan

WGCPARIS2015

WORLD GAS CONFERENCE

"GROWING TOGETHER TOWARDS A FRIENDLY PLANET"

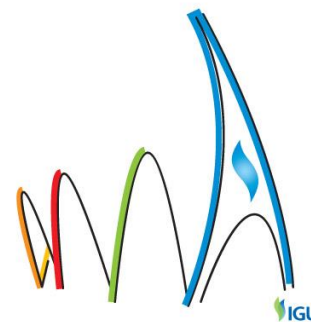

26th World Gas Conference | 1-5 June 2015 | Paris, France

Table of Contents

Table of Contents	1
1. Introduction.....	2
2. Aim.....	3
3. Advantage of new models	10
4. Results	14
5. Summary.....	14
6. Acknowledgement	14

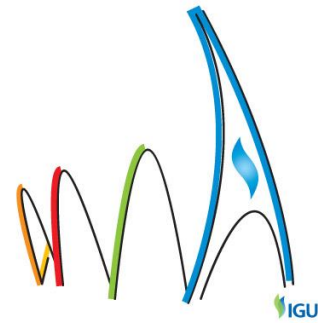

1. Introduction

Tokyo Gas has been developing residential PEMFC (Proton Exchange Membrane Fuel Cell) micro-CHP systems with Panasonic Co. from 1998. After “the Large Scale Demonstration Project” (2005-2008) conducted by NEF (New Energy Foundation) / NEDO (New Energy and Industrial Technology Development Organization) and supported by METI (Ministry of Economy, Trade and Industry), Tokyo Gas released its first commercial model of a residential PEMFC micro-CHP system in 2009 by the name of “ENE-FARM” that is a common trademark in Japan. The second-generation model was released in April 2011, followed by a third iteration in April 2013. Each new release has brought performance, installability, and cost improvements, and a total of 40,000 units had been sold as of January 2015, which is the top share in Japanese whole sales value of 110,000.

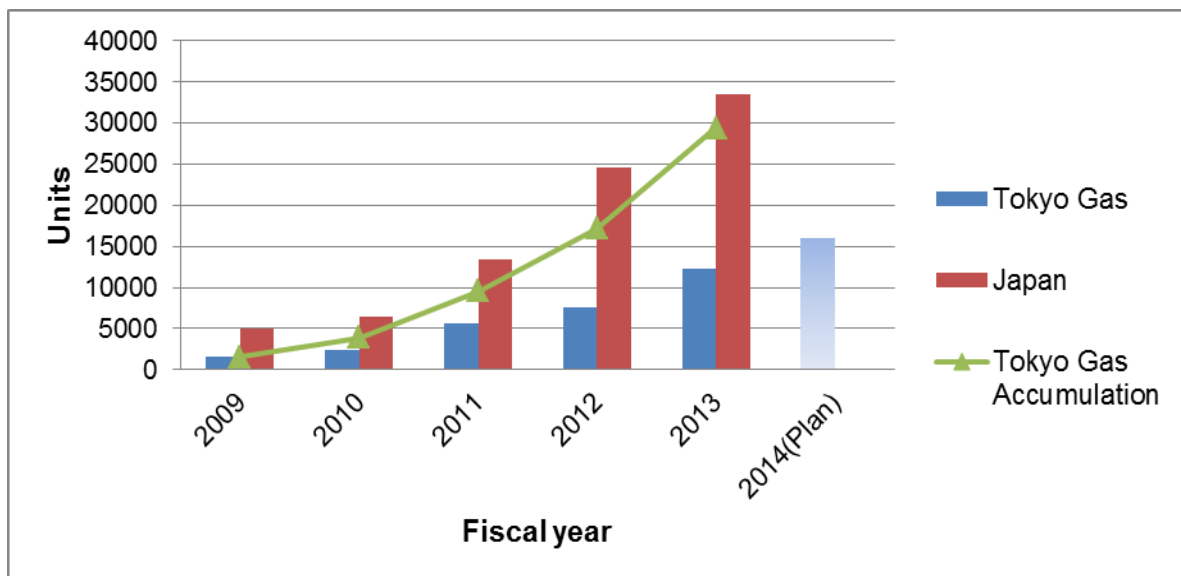
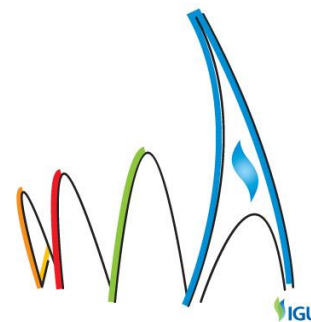

Fig 1: Sales results and plan of ENE-FARM

While sales growth to date has been promoted by government subsidies, further cost reductions will be needed to be achieved through efficiencies of scale if ENE-FARM sales are to really launch. Characteristically in the urban area in Japan, homes in apartment buildings are growing in larger proportion as shown in Table 1. To broaden the potential market, therefore, Tokyo Gas decided to develop and market a new model, based on its detached houses model that would be installable in apartment buildings as well as detached dwellings as to date.



A public demand for greater energy security to counter concerns about supply continuity in the wake of the 2011 earthquake and outages caused by lightning strikes, typhoons, heavy snow, and other meteorological events is growing. In order to meet the public demand, the decision was also taken to develop and market an optional power continuity switch and power supply to allow electricity to continue to be generated in the event of a power outage.

This paper reviews our newly developed systems and optional units for "ENE-FARM", with their specifications and merits.

Table 1: Amount of new houses construction in 2013

Place	Detached households	Apartment households	Total
Japan	597,222 (60%)	390,032 (40%)	987,254
Tokyo met.	54,652 (37%)	93,326 (63%)	147,978
Kanagawa pref.	36,389 (47%)	40,970 (53%)	77,359

Calculated using residence statistic report by the Ministry of Land, Infrastructure, Transport and Tourism, Japan

2. Aim

2.1. Development of apartment buildings model of ENE-FARM

2.1.1. Specifications

A typical installation image of the new model ENE-FARM is shown in Figure 2, and its specifications are compared with those of the conventional model (for detached houses) in Table 2. The power output and efficiency of the two models are the same. The user interface of colour remote controller, which is also the same as that of the conventional one, is shown Figure 3. Note that the new model offers improved wind and earthquake resistance, making it better suited to be installed in apartment buildings, where there exist greater installation constraints than in detached houses.

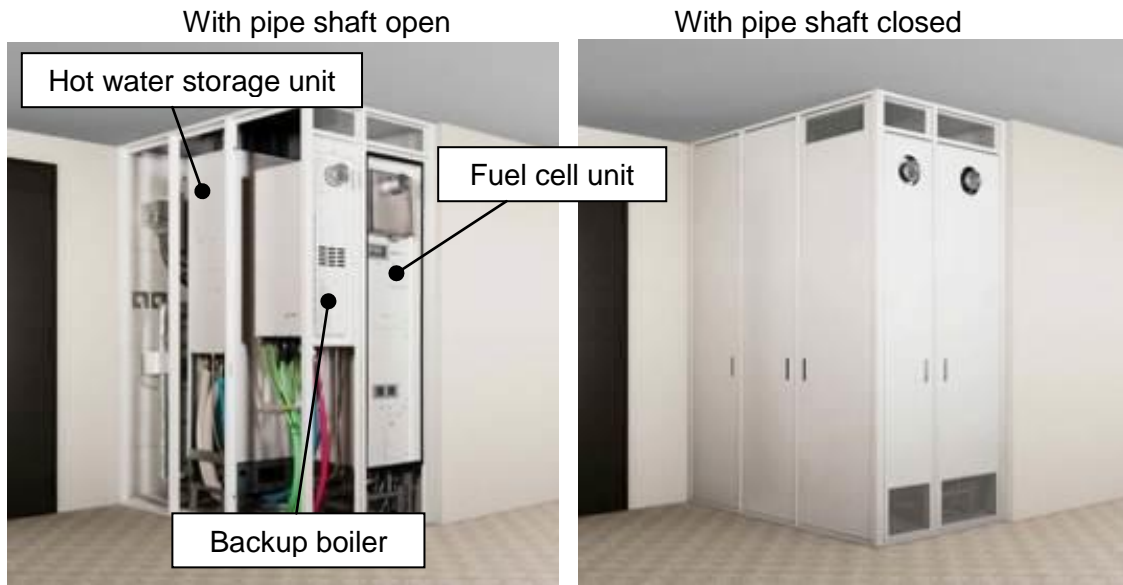

Fig 2: Image of ENE-FARM installed in a pipe shaft of apartment buildings



(a)

(b)

Fig 3: User interface of remote controller for (a) kitchen, and (b) bathroom

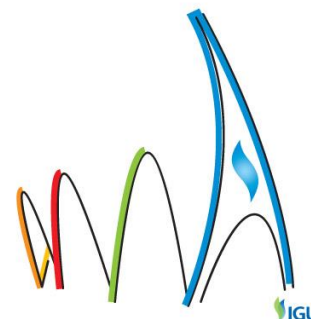

Table 2: Specifications of apartment buildings and detached houses modes of ENE-FARMI

		Apartment buildings model	Detached houses model (conventional)
Performance	Power generation output	200W-750W	←
	Electrical efficiency	39.0%LHV / 35.2%HHV	←
	Heat recovery efficiency	56.0%LHV / 50.6%HHV	←
	Overall efficiency	95.0%LHV / 85.8%HHV	←
	Tank capacity	147L	←
	Wind resistance	30m/sec	15m/sec
	Earthquake resistance	1.0G	0.4G
Dimensions	Fuel cell unit	H 1750mm W 399mm D 395mm	H 1850mm W 400mm D 400mm
	Hot water storage unit	H 1850mm W 560mm D 400mm	←
Weight (dry)	Fuel cell unit	99kg	90kg
	Hot water storage unit	54kg	55kg

2.2. Development of optional units for power outage

2.2.1. Specifications

We developed two types of optional units which can be adapted to ENE-FARM and serve in the event of power outage. Appearances of these devices are shown in Figure 4 and Figure 5, and also their specifications are summarized in Table 3.

One, named "Option A", has a switch unit which enables ENE-FARM to continue generating and supplying electricity to the home via an emergency outlet in the event of a grid power outage. This functionality is provided by a device that automatically switches the generated power feed from the distribution board during normal use to emergency outlets in an outage.

The other type, "Option B", has been developed in order to start up ENE-FARM that is not generating in the event of a grid power outage. This option is composed of a switching unit and a power supply unit. In addition to the function that automatically switches the generated power feed from the distribution board during normal use to identified outage use, this option supplies necessary power to the sleeping ENE-FARM for starting up themselves (black out start, BOS).



Fig 4: Appearance of Option A

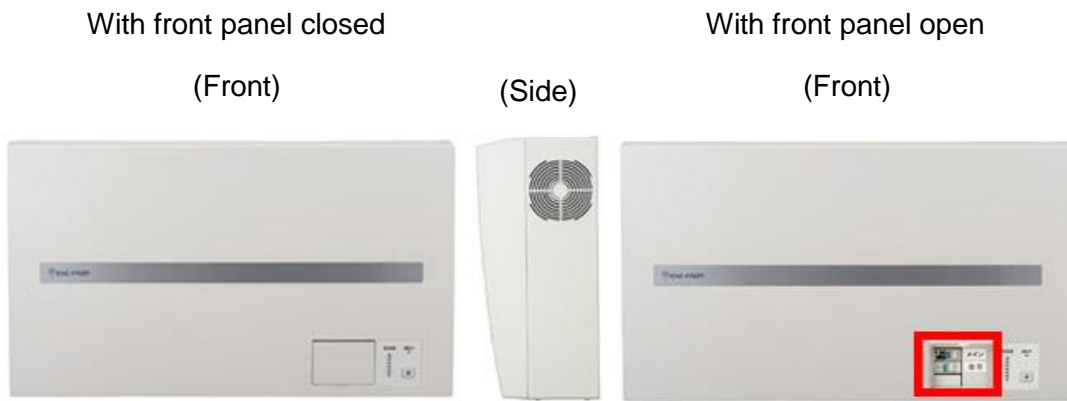

(a) Power supply unit



(b) Switching unit

Fig 5: Appearance of Option B (a) Power supply unit (b) Switching unit

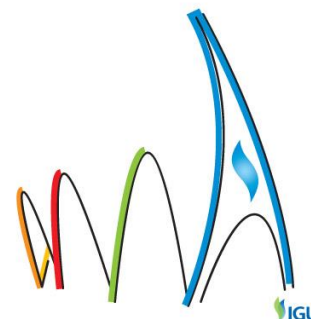

Table 3: Specifications of optional units for power outage

		Option A	Option B
Parts description	Unit name	Switching unit	(1)Power supply unit (2)Switching unit
	Dimensions / weight	H325xW485xD155 / 13kg	(1) H350xW605xD155 / 20kg (2)H325xW485xD155 / 14kg
	Installation Location	Indoor wall-mounted	←
Performance	Continuing FC generation	○	←
	Starting up FC	×	○
	Max. inverter output on grid power outage	FC : 750W	FC : 750W Power supply unit : 500W (1000Wh capacity)
	Max. available power on grid power outage	Approx. 700W	Approx. 1200W
	Approx. supply duration on grid power outage	Max. 4 days (96hours) from start of generation before outage	Load until 700W : Max. 4 days from start of generation before outage Load until 900W : Max. 10 hours Load until 1200W : Max. 2 hours
	In outage, power supply to	Emergency outlet Hot water storage unit Back up boiler	Usual identified outlet Hot water storage unit Back up boiler
Retail price		JPY 130,000	(1)JPY 472,000 (2)JPY 143,000

2.3. Development of new detached houses model of ENE-FARM (fourth generation model)

2.3.1. Specifications

The fourth generation model is shown in Figure 6, and their specifications are compared with those of the conventional model (the third generation) in Table 4. The power output of the new model decreased from 750 to 700W aiming more compatibility to present Japanese houses, with maintaining the efficiency. Corresponding to the variety of system installation, two types of the Hot water storage unit are prepared. One is a separation type, and the other combined type, of backup boiler with hot water tank. Downsizing and cost reduction of the system are done as well.

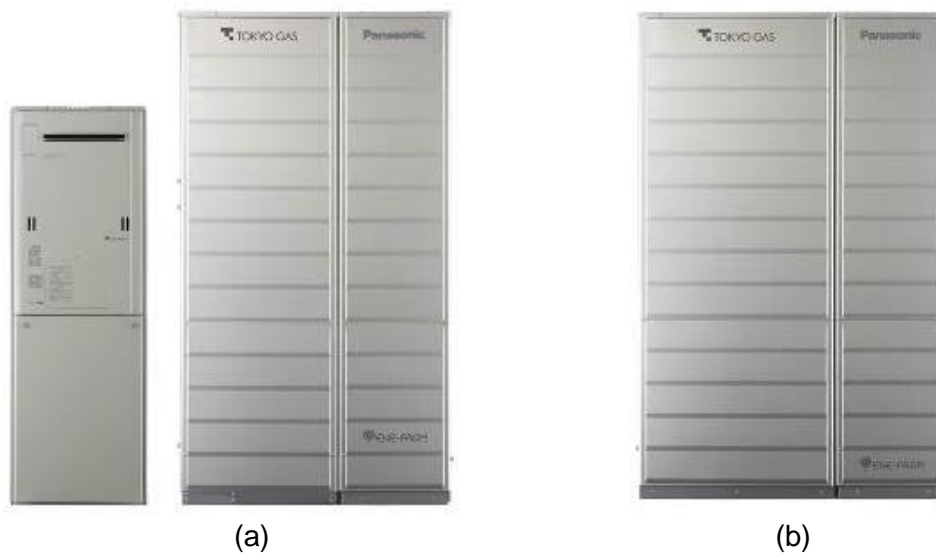

Fig 6: Appearance of fourth generation model (a) Separation type (b) Combined type

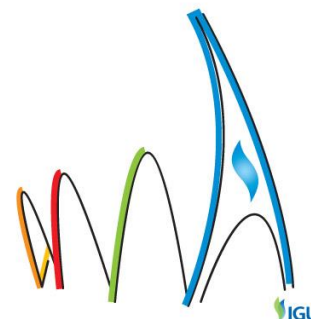

Table 4: Specifications of fourth and third generation model of ENE-FARM for detached houses use

		4G model	3G model (conventional)
Performance	Power generation output	200W-700W	200 W-750W
	Electrical efficiency	39.0%LHV / 35.2%HHV	←
	Heat recovery efficiency	56.0%LHV / 50.6%HHV	←
	Overall efficiency	95.0%LHV / 85.8%HHV	←
	Tank capacity	140L	147L
Dimensions	Fuel cell unit	H 1750mm W 400mm D 400mm	H 1850mm W 400mm D 400mm
	Hot water storage unit Separation type	H 1750mm W 560mm D 400mm	H 1850mm W 560mm D 400mm
	Hot water storage unit Combined type	H 1750mm W 700mm D 400mm	-
Weight (dry)	Fuel cell unit	77kg	90kg
	Hot water storage unit Separate type	50kg	55kg
	Hot water storage unit Integrate type	88kg	-
Retail price		JPY 1,600,000	JPY 1,900,000

3. Advantage of new models

3.1. New model for apartment use

(1) Installable in pipe shafts

Design improvements including more gastight units and thicker external panelling materials allow the fuel cell unit, hot water storage unit, and backup boiler to be installed in pipe shafts facing onto open passageways. The fuel cell unit's exhaust and other ports have also been combined into one, allowing installation in pipe shaft access hatches, and the fuel cell unit and backup boiler now look more integrated when arranged side by side. One instance is shown Figure 7.

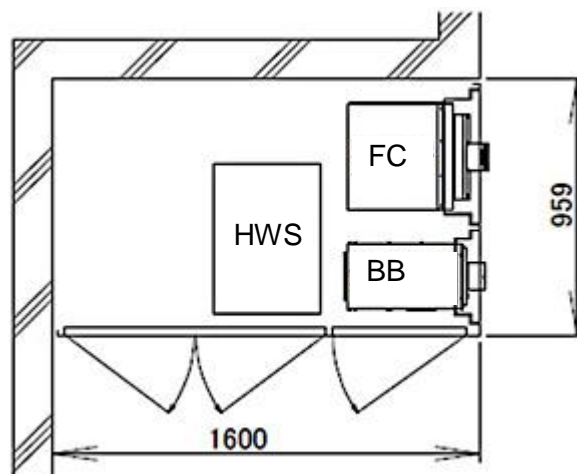

Fig 7: An Example of installation layout of ENE-FARM installed in a pipe shaft

(2) Complies with requirements for apartment installation

Earthquake resistance has been enhanced by strengthening the legs anchoring the units in order to meet building installation requirements. Then ENE-FARM have borne for 1.0G, compared the old model borne for 0.4G.

The design has also been made more wind resistant by bundling the fuel cell unit's air feed and exhaust ports together and mitigating the effects of wind pressure on the internal components, is shown Figure 8, allowing the system to operate even in 30 m/s winds so it can be installed in high-rise buildings too.

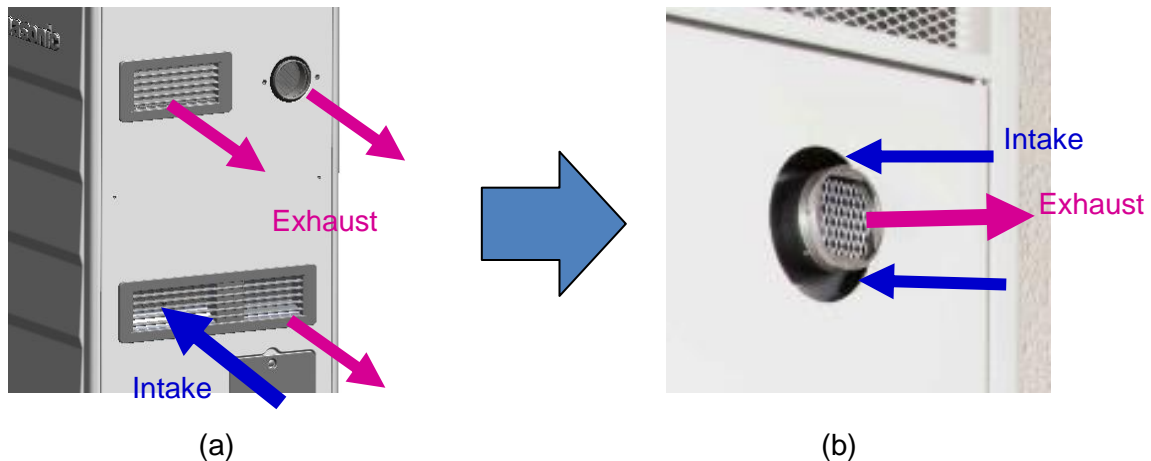

Fig 8: Construction of intake/exhaust: (a) conventional model, and (b) apartment houses model

(3) Suited to variety of installation configurations

As well as installing the fuel cell unit, hot water storage unit, and backup boiler together in one pipe shaft, the three units can also be located separately in different shafts. By providing multiple exhaust options for the fuel cell unit and backup boiler, and also offering a slim-type backup boiler as well as a standard one, the system can be installed in various kinds of ways in apartment buildings.

3.2. Optional units for power outage

(1) During normal use

In order to function, ENE-FARM needs power from the grid at start up and also to make up the shortfall in homes that consume more electricity than the system can provide. During normal use, therefore, ENE-FARM supplies power to the home via the distribution board in combination with grid power by tracking the electrical demand and using the voltage and frequency of grid power for its reference voltage. The flow of electricity during normal use and power outage of Option A and Option B are shown in Figure 9 and Figure 10, respectively. In Option A, electricity does not flow to the emergency outlet, while in Option B; it flows to the identified outlet. The Power supply unit of Option B is also charged but never supplies power to the other loads.

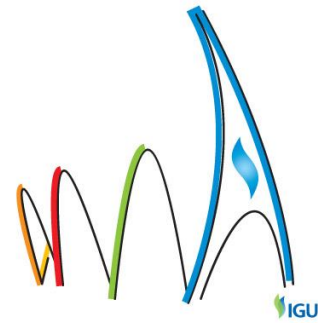

(2) During grid power outage

When ENE-FARM is in operation at the event of grid power outage, it survives from shutdown and continues power generation, if it equips either Option A or Option B. The power continuity switch in the options bypasses the distribution board and feeds power generated by ENE-FARM directly to the emergency outlets (by Option A) or identified outlets (by Option B). Examples of the home appliances that can be powered by ENE-FARM in grid power outage include LED lights, chargers for mobiles phones, gas appliances such as water heaters and floor heating systems.

When ENE-FARM is NOT in operation at the event of grid power outage, ENE-FARM can start up and supply power if it equips Option B. ENE-FARM is able to start autonomously by receiving power supply from the lithium ion battery built-in the Power supply unit. Note that you can use only emergency light during starting-up process of ENE-FARM until it starts power generation.

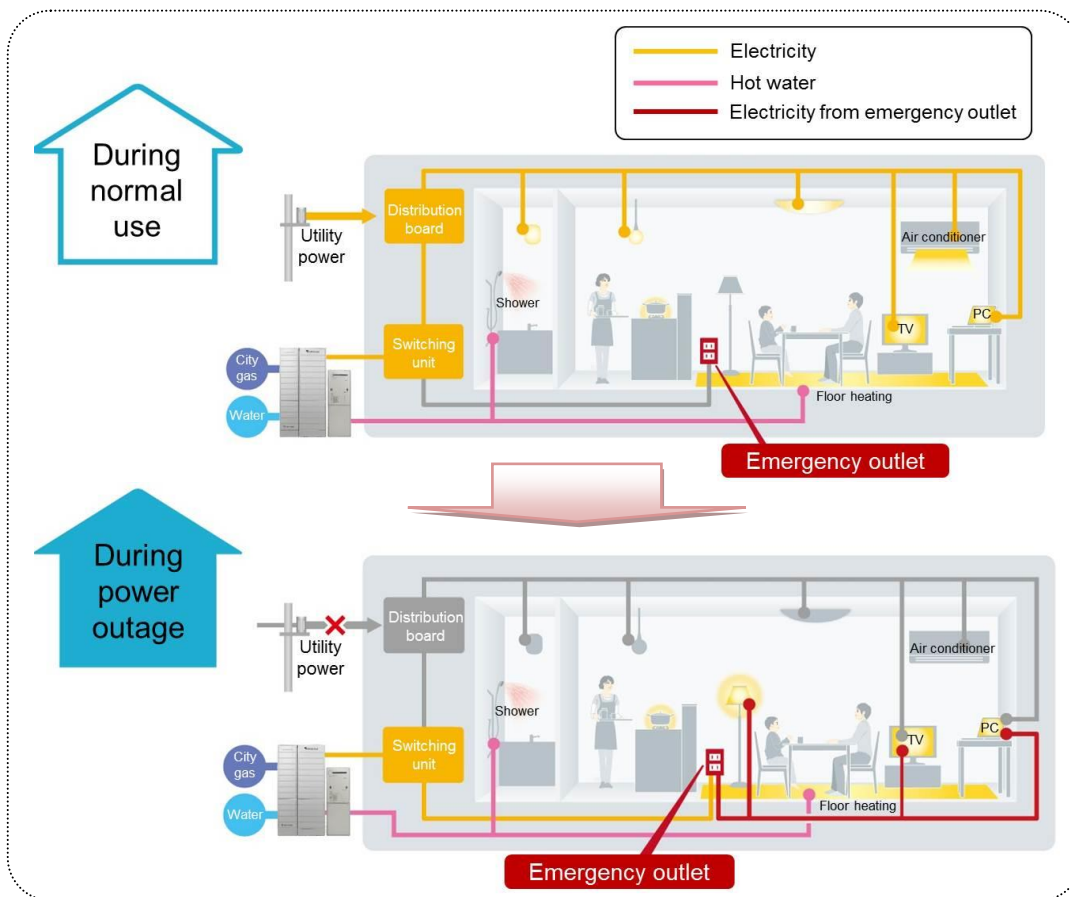

Fig 9: Flow of electricity of Option A

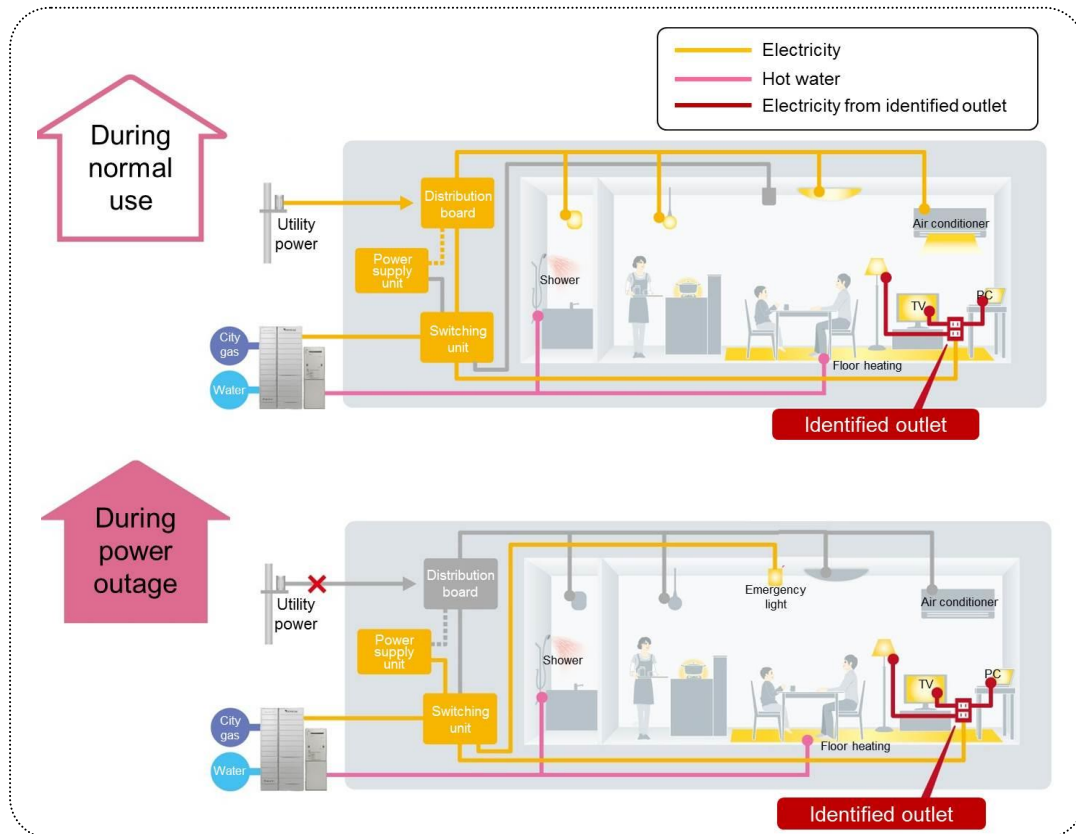

Fig 10: Flow of electricity of Option B

3.3. New detached houses model (fourth generation)

(1) Cost reduction

The new model realized cost reduction of 300,000 yen from 1,600,000 yen of the retail price for the present model (third generation), by renovating the inside construction such as cell stack and by a reduction of the number of components by approximately 15% in comparison with a current model.

(2) Improvement of installability

Preparing two variations of the hot water storage units enabled system installation capability especially in urban areas where available space is small and complicated.

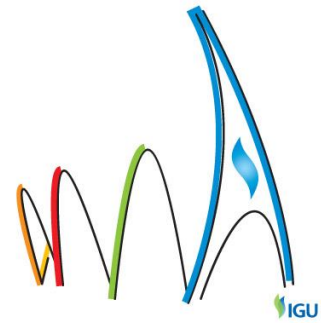

4. Results

In order to expand the potential market of ENE-FARM, we developed new systems and optional units. One is an apartment buildings model of ENE-FARM, developed by means of modifying the conventional model for detached houses such as on wind and earthquake resistance, so that it can be installed in the apartment buildings including high-rise ones that are commonly built in the urban area. The system was released in April 2014.

The second is optional units which enable ENE-FARM to continue generating electricity during a power outage were also developed to meet customer needs. Option A was released in April 2014 and Option B was released in October 2014.

Finally a new model for detached houses with two variations of hot water storage units was developed, and is to be launched in April 2015.

5. Summary

In fiscal 2014, Tokyo Gas aims to sell 16,000 units, of which 500 are projected to be orders for ENE-FARM systems for apartment buildings. And more systems are intended to be sold in following years. Development will continue to be pursued in order to further expand ENE-FARM's adoption and so contribute more to protecting the global environment and stable energy supply.

6. Acknowledgement

Our deepest appreciation goes to METI, NEDO and NEF for their continuous support to development and introduction of ENE-FARM.